

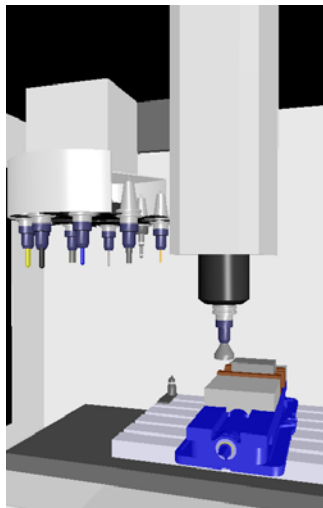

Virtual Training Environment CNC Machining

Flight Simulator Technology

The Virtual Training Environment for CNC Machining combines *powerful* "flight-simulator" technology with a *flexible* Internet-based learning content management system to deliver a truly innovative learning experience.

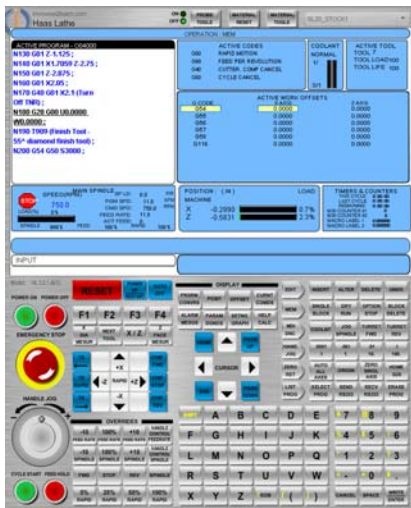

Simulated 3D machine models

Mimic Reality

- Virtual mills and lathes
- Industrial control panels
- Edit, load, run and save NC programs
- Set tool and work offsets
- Touch probes
- Stock material removal
- Canned cycles
- Control alarms

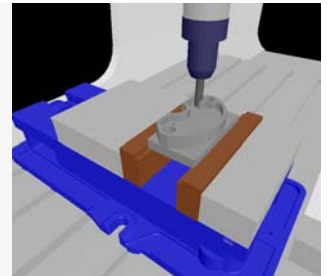

Real-time material removal

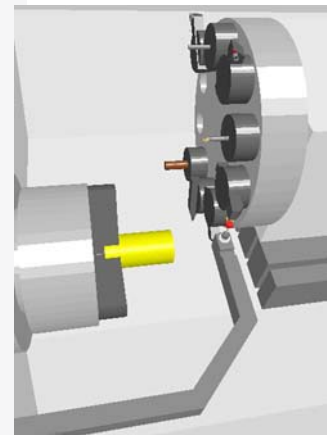

Mill and lathe touch probes

Learning Productivity Tool

Unlimited access to train and rehearse in the Virtual Training Environment for CNC machining enables learners to develop greater confidence and proficiency prior to performing actual procedures and operating equipment.

Learn at Your Convenience!

Learn CNC machine setup and programming with popular control panels for Haas Machine Tools.

Major Benefits

- Cost-effective and safe
- 24/7 access at your convenience
- Track and measure learner progress
- Reduce risk to people and equipment
- Increase control panel training contact-time
- Learn with virtual controls and 3D machines

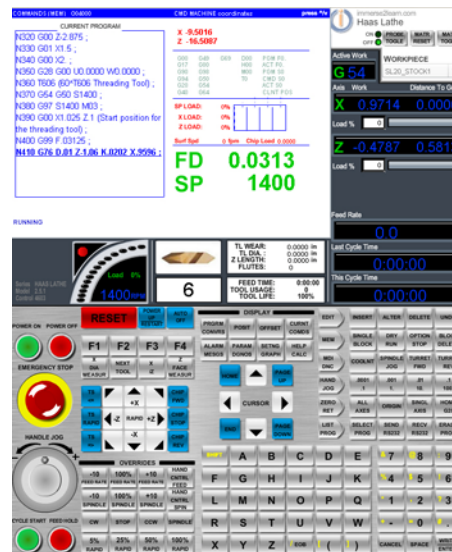

Popular control panels

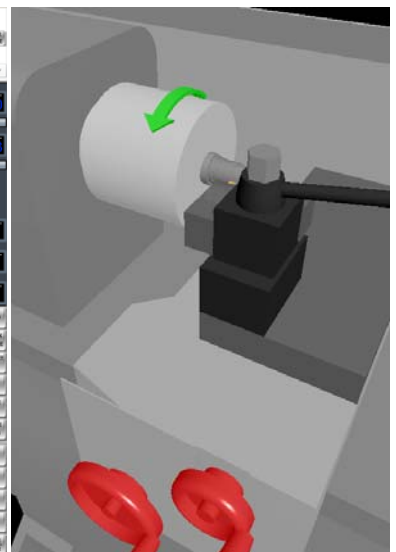

Lathe applications



Powered by Immerse2learn.com

Additional Products

Online Learning Courses and Virtual 3D CNC Machine

Mill and *Lathe* CNC online courses provide the learner with comprehensive learning content, interactive exercises and virtual CNC panels and 3D machines. Depending on the course selected learning modules may include:

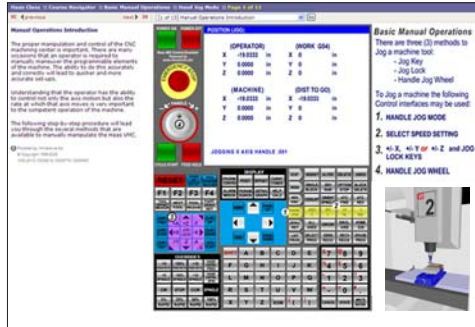
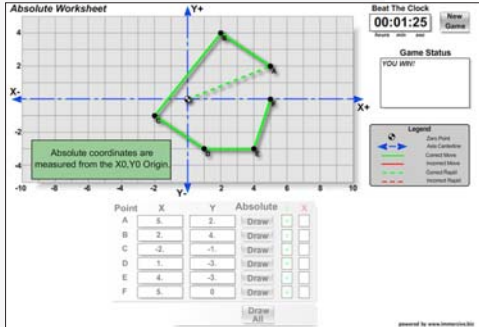

Setup

- Machine Motion Description
- CNC Panel Interface
- Machine Start-up
- Manual Operations
- Job Setup
- Edit Capabilities
- Program Entry
- Program Run

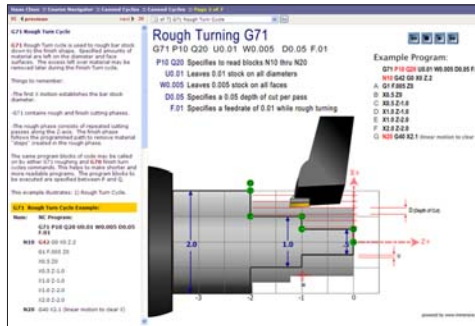
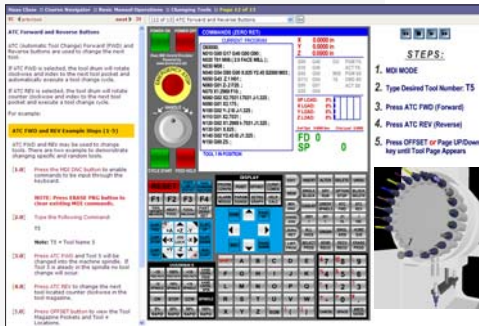

Programming

- Codes and Programs
- Program Structure
- Cartesian Coordinates System
- Cutter Compensation
- Tool Nose Radius Compensation
- Circular Interpolation
- Hole Manufacturing
- Programming Labs

Interactive online courses

Color Manuals, Exercises and Projects

Mill CNC Programming Level 1

An introduction to codes and programming, this manual is designed for beginner to intermediate level *Mill* CNC operators and programmers. The content and sample programs provided cover a broad range of CNC programming requirements. Basic mathematics and formulas are used.

Lathe CNC Programming Level 1

An introduction to codes and programming, this manual is designed for beginner to intermediate level *Lathe* CNC operators and programmers. The content and sample programs provided cover a broad range of CNC programming requirements. Basic mathematics and formulas are used.

Mill CNC Programming and Applied Mathematics Level 2

This intermediate to expert level manual provides much more advanced application of codes, programming, and use of canned cycles. The content and sample programs provided cover a broad range of CNC programming requirements. Advanced mathematics and formulas including applied shop floor trigonometry and geometry are used.

Other Products and Services

- Robotic simulation
- Learning content management system
- Online evaluation tools
- Content development
- Onsite training
- CNC programming

